

OWNER'S MANUAL

RAIDER MAX 175-S/D
(Single/Double Seat)

EEC APPROVED ON ROAD



Limited Warranty

The warranty policy applies to those cases where the new seller vehicle unloaded from its shipping container, set up and delivered by authorized dealer and under normal use and service is found to have defects in parts or workmanship under the following terms and conditions. This warranty covers the engine and engine related components for a period of 180 days from the date of purchase.

This warranty does not apply to any parts that in the seller's opinion were defective because of improper maintenance, improper assembly, alterations, abuse, negligence, usage of non-genuine parts or accidents.

Should warranty service be required on your vehicle during the 180-day warranty period, please contact your nearest authorized DAZON dealer for repairs.

What is not covered under this warranty?

This warranty does not cover any seller vehicles that have been subjected to:

- a. Renting;
- b. Disassembly, adjusting or repairing of the vehicle in any way so as to adversely affect its safety or reliability;
- c. Competition or racing.

The warranty does not cover any losses of the seller vehicle use, any losses of time, any inconveniences, or any other consequential damages which include, but are not limited to the losses or damages to any persons, property or expenses of returning damaged units to the vehicle distributor or any **DAZON** authorized dealers.

DAZON has the right to make changes without prior notice.

Contents

1. Foreword-----	5
2. A Few Words about Safety-----	6
3. Important Safety Information-----	8
4. Safety Labels-----	12
5. Are You Ready to Drive? -----	13
6. Is Your Vehicle Ready to Drive? -----	18
7. Safe Driving Precautions-----	21
8. Operation-----	24
9. Service Instructions-----	39
10. Repairs-----	47
11. Periodical Checks and Services-----	48
12. Optional Parts-----	49
13. Specifications-----	54
14. Wiring Diagram -----	59

FOREWORD

Thank you for choosing our **Raider Max 175** that is **approved by EEC for on-road use**. We hope you will have fun with it. Before starting operate this vehicle, please read through this Owner's Manual carefully as it contains important safety and maintenance information. Failure to follow the warnings contained in this manual can result in serious injuries.

Be sure to follow the recommended maintenance schedule and service your vehicle accordingly. Preventive maintenance is extremely important to the longevity of your **Buggy**.

Beginners should drive this vehicle in a large open area to practice handling it. Wear protective gears all the time when driving or riding this vehicle.

We hope you will have a pleasant experience with our products and thanks again for choosing **DAZON**.

A FEW WORDS ABOUT SAFETY

In order to keep everyone safe, you must take responsibility for the safe operation of your **Buggy**. To help you make informed decisions about safety, we have provided operating procedures and other information on labels in this manual. This information alerts you to potential hazards that could hurt you or others.

It is not practical or possible to warn you against all hazards associated with operating or maintaining your **Buggy**, so you must use your own good judgments.

You will find important safety information in a variety of forms, including:

- ★ **Safety Labels** -----on the vehicle;
- ★ **Safety Messages** ----- preceded by a safety alert symbol  and one of the two signal words “**WARNING**” or “**CAUTION**”;
- ★ **The meaning of these signal words:**
 - WARNING** -----Physical harm may result from the failure to follow the instructions that are described within the labels;
 - CAUTION**----- Damages to your vehicle and possible subsequent personal injuries or death could result

from the failure to take proper precautions described within the labels;

- ★ **Safety Headings**-----such as Important Safety Reminders or Important Safety Precautions;
- ★ **Safety Sections**-----such as **Buggy** Safety;
- ★ **Instructions**-----about how to use this vehicle correctly and safely.

The whole manual is filled with important safety information, so **please read it carefully.**

IMPORTANT SAFETY INFORMATION

Your **Buggy** will provide you with many years of service and pleasure, providing you take responsibility for your own safety and understand the challenges you will meet while driving.

There is much that you can do to protect yourself when driving your vehicle. You'll find many helpful recommendations throughout this manual. The following are a few of the most important ones.

Follow the Age Recommendation

It is strongly recommended that no one under age of 16 be permitted to drive this **Buggy** without adult supervision.

Always Wear a Helmet

Facts have proven that helmets can significantly reduce the quantity and severity of head injuries, so when you drive your **Buggy**, please always wear an E-Mark approved motorcycle helmet. We also recommend that you wear approved goggles, sturdy boots, durable gloves and other protective gear.

Take Time to Learn & Practice

Even if you have driven other buggies, you still should take time to become familiar with how this vehicle works. Practice in a safe area until you have built your skills and gotten accustomed to this vehicle's size and weight.

Because many accidents have involved inexperienced or untrained drivers, we urge all drivers to take a training course approved by the Buggy Safety Institute. Check with your dealer for more information on the training course.

Be Alert to Hazards

The terrain can present a variety of challenges when you drive. Continually "read" the terrain for unexpected turns, drop-offs, rocks, ruts and any other hazards. Always keep your speed low enough to allow time for seeing and reacting to hazards.

Drive within Your Limits

Pushing limits is another major cause of **Buggy** accidents. Never drive beyond your personal abilities or faster than conditions warrant. Remember that alcohol, drugs, fatigue and inattention can significantly reduce your ability to make good judgments and to drive safely.

Don't Drink and Drive

Alcohol and drive never mix. Even one drink can reduce your ability of responding to changing conditions, and every additional drink can lengthen and worsen your reaction time. So don't drink and drive, and don't let your friends drink and drive either.

Never Drive Indoors

The exhaust from the engine contains a tasteless, odorless but poisonous gas called carbon monoxide. For the health of your family, please don't drive your **Buggy** in your lovely house.

Keep away from Moving Parts

You should never place your hands or any other parts of your body near any moving parts of your vehicle. Failure to adhere to this warning will cause physical harm to your body.

Avoid Skidding or Sliding

The terrain surface can be a major factor affecting turns. Skidding or sliding a turn is more likely to occur on slippery surfaces such as snow, ice, mud and loose gravel. If you skid or slide on ice, you may lose all directional controls. To avoid skidding or sliding on slippery terrain surfaces, you should keep your speed low and drive carefully.

Limited Loadage

The limited loadage on the rear rack is 10kg or 22lbs.

This section presents some of the most important information and recommendations to help you drive your **Buggy** safely. **Please take a few minutes to read it.**

SAFETY LABELS

The labels should be considered permanent parts of your **Buggy** . If a label comes off or becomes difficult to read, please contact your dealer for warning label replacements.



ARE YOU READY TO DRIVE?

Before each drive, you need to make sure that you and your **Buggy** are both ready to drive. To help you be prepared, this section discusses how to evaluate your driving readiness, what items you should check on your vehicle, and how to adjust your vehicle for your comfort, conveniences and safety.

Before driving your **Buggy** for the first time, we urge you to:

- Carefully read this owner's manual and the labels on your vehicle;
- Make sure that you understand all the safety messages;
- Learn how to operate all the controls on your vehicle;
- Ask for adult supervision if you are under 16 years old.

Before each of your drive, we urge you to be sure that:

- You feel well and you are in good physical and mental conditions;
- You are wearing an E-Mark approved motorcycle helmet (with a chin strap tightened securely), approved goggles and other protective gear;
- You don't have any alcohol or drugs in your body system.
- You have a driver's license.

Protective Apparel

For your safety, we strongly recommend that you always wear an E-Mark approved motorcycle helmet, goggles sturdy boots, durable gloves, long pants and long-sleeved shirt or jacket whenever you drive.

Although complete protection is not possible, wearing proper protective apparel can reduce the chances of injuries when you drive.

The following suggestion will help you choose the proper driving gear.

1. Helmets and Eye Protection Gear

Your helmet is your most important driving gear because it offers the best protection against head injuries. Your helmet should fit your head comfortably and securely. An open-face helmet offers some protection, but a full-face helmet offers more. Regardless of the style, look for the helmet with an E-Mark Approve sticker.

Always wear a face shield or a pair of goggles to protect your eyes and vision.

2. Additional Driving Gear

In addition to a helmet and eye protection gear, we also recommend:

- Sturdy motorcycle boots to help protect your feet, ankles and lower legs;
- Durable motorcycle gloves to help protect your hands;
- Driving pants with knee and hip pads, a driving jersey with padded elbows, and a chest and shoulder protector.



- **Operating this BUGGY without wearing an approved motorcycle helmet, eye protection gear, or any protective apparel could increase your chances of head and/or eye injuries, and even possibly death in the event of severe accidents.**
- **Always wear an approved motorcycle helmet, an eye protection gear (goggles or a face shield), a long-sleeved shirt or jacket, gloves, boots and long pants.**

Driver Training

Developing your driving skills is an on-going process. Even if you have driven other Buggies, you still need take time to become familiar with how this **Buggy** works. Practice driving this vehicle in a safe area to build your skills. Don't drive on rough terrain surfaces until you've gotten accustomed to all the controls on this vehicle, and felt comfortable with its size and weight.

 **WARNING**

- **Operating this BUGGY without proper instructions could increase your risks of accidents that could lead to serious injuries, or even death.**

Age Recommendation

It is strongly recommended that no one under age of 16 be permitted to operate this **Buggy** without adult supervision.

 **WARNING**

- **A child driving a BUGGY that is not recommended for his/her age could lose the vehicle control and result in severe injury or death.**
- **A child under 16 should have adult supervision when operate on the vehicle.**

No Alcohol or Drugs

Alcohol, drugs and Buggies never mix. Even a small amount of alcohol can impair your ability to operate your **Buggy** safely.

Likewise, drugs, even prescribed by your doctor, can be dangerous when you're operating your vehicle.

Consult your doctor for the assurance that it is safe to operate your vehicle after taking some kind of medication.



- **Operating this BUGGY after consuming alcohol or drugs can seriously affect your judgments, cause you to react more slowly, affect your balance and perception, and even could result in serious injuries or death.**
- **Never consume alcohol or drugs before or while operating your vehicle.**

IS YOUR VEHICLE READY TO DRIVE?

Before each of your drive, it is important to inspect your **Buggy** and make sure that any problems you've found have been corrected. A pre-drive inspection is a must, not only for safety, but also because a breakdown, or even a flat tire, can be a major inconvenience.

If your **Buggy** has overturned or has been involved in a collision, please don't drive it until your dealer has inspected it. There may be damages or other problems you can't see.



- **Improperly maintaining your BUGGY or failing to correct a problem before driving can cause a crash in which you can be seriously hurt or even killed.**
- **Always perform a pre-drive inspection before each of your drive, and correct any problems.**

Pre-Drive Inspection

Please check the following items before getting on your **Buggy**:

- *Engine Oil:* Check the level and add oil if needed; check for leaks; don't let any water go into the

engine, otherwise the engine can't start;

- *Fuel:* Check the level and add fuel if needed, and make sure the fuel-filling cap is securely fastened; check for leaks.
- *Tires:* Use a gauge to check the air pressure, adjust the tires if needed; look for signs of damages or excessive abrasion.
- *Nuts & Bolts:* Check the wheels and all the accessible parts to see if the nuts, bolts, and fasteners are tightened; use a wrench to tighten them if needed.
- *Underbody & Exhaust System:* Check for any dirt, vegetation or any other debris that could cause fire hazards or interfere with the proper operation of your Buggy, and remove them.
- *Air Cleaner Housing Drain Tube:* Check for carbon deposits in the drain tube; if necessary, clean the tube and check the air cleaner housing.
- *Leaks & Loose Parts:* Walk around your Buggy and look for anything that appears unusual, such as a leak or a loose cable; repair or replace the concerned parts if needed.
- *Lights:* Make sure the headlights, brake lights; turning lights, rear license light and taillights etc. work properly.
- *Throttle:* Check the free play and adjust the throttle if needed; press the throttle to make sure it moves

smoothly without sticking, and release it to make sure it snaps back automatically.

- *Brakes*: Press the rear brake pedal several times, and check the brake pedal free play; make sure there is no brake fluid leakage.
- *Engine Stop Button*: When the engine is running, press and hold the Engine Stop Button for two seconds to see if the engine stops.
- *Steering Wheel*: Turn the steering wheel to see if it turns properly.
- *Cable*: Check the cable housing for wear and check the fittings for looseness; replace or tighten the concerned parts if needed.
- *Horn*: Make sure that the horn works properly.
- *Cooling System*: check if the cooling system can work properly after the engine has started.

SAFE DRIVING PRECAUTIONS

Keep Your Hands and Feet on Controls

Always keep both of your hands on the steering wheels ,and both of your feet on the foot controls when driving your **Buggy**. It is important to maintain your balance and control your vehicle. Removing your hands or feet away from the controls can reduce your ability of controlling your vehicle.



WARNING

- **Removing your hands from the steering wheels, or your feet from the foot controls during operation, can reduce your ability of controlling your BUGGY, or cause you to lose your balance and fall off your BUGGY.**
- **During operation, always keep your both hands on the steering wheels, and your both feet on the foot controls of your BUGGY.**

Control Speed

Driving at excessively high speed increases the chances of accidents. When choosing a proper speed, you need to consider the capability of your **Buggy**, terrain, visibility and other operating conditions, plus your own skills and experiences.

 **WARNING**

- **Operating your BUGGY at excessively high speed increases your chances of losing control, which can easily result in an accident.**
- **Always drive at a speed that is proper for your BUGGY, terrain, visibility and other operating conditions, plus your own skills and experiences.**

Be Careful on Unfamiliar or Rough Terrain

Before driving in a new area, always check the terrain thoroughly. Don't drive fast on unfamiliar terrain or when the visibility is limited. (Sometimes it's difficult to gain the reaction time before you see obstructions like hidden rocks, bumps, or holes in time to react.)

 **WARNING**

- **When driving your BUGGY on unfamiliar terrain, failure to be especially careful could cause your vehicle to go out of control or overturn.**
- **When operating your BUGGY on unfamiliar terrain, always drive slowly, always be especially careful, and always be alert to changing terrain conditions.**

Never drive past the limit of visibility. Maintain a safe distance between your **Buggy** and other vehicles. Always exercise your cautions and use your extra care on rough, slippery and loose terrain.

 **WARNING**

- **Failure to use your extra care when operating on excessively rough, slippery or loose terrain could cause loss of traction or vehicle control, which could result in accidents, including an overturn.**
- **Don't operate on excessively rough, slippery or loose terrain until you've learned and practised the skills necessary to control your BUGGY on such terrain.**
- **Always be especially cautious on these kinds of terrain.**

Don't Perform Stunts

You should always operate your **Buggy** in a safe and reasonable manner. When driving, always keep all of the four wheels on the ground.

 **WARNING**

- **Attempting wheelies, jumps, and any other stunts increases the chances of accidents, including an overturn.**
- **Never attempt stunts, such as wheelies or jumps. Don't try to show off.**

OPERATION

A. Operation Controls

Don't attempt to start or operate the engine until you've been completely familiar with the location and use of each control that is necessary to operate your **Buggy**. You must know how to stop it before starting and driving.

a. Throttle

The right foot pedal is the throttle that controls your vehicle speed. As the engine speed is above idle, the clutch automatically engages and moves the vehicle forward. To disengage the clutch at any time, allow the throttle to return to the idle position.



- Each time before starting the engine, check the throttle assembly to ensure that when you push the pedal all the way forward, the throttle assembly is working smoothly, and when you release the pedal, the throttle assembly returns to idle. Don't operate if the pedal or throttle linkage fails to return to the idle position.
- If you're unable to correct the problem through lubrication, adjustment or replacement of worn parts, please contact your dealer for assistance.

b. Brake

The brake is located on the left side of the vehicle. Applying pressure to the pedal can draw the brake calipers around the brake pumps (one at the rear wheel, two at the front wheel), and slows or stops your vehicle.



c. Control Panel

Left Part -----three instruments:

- **Water Temperature Indicator**----- It's on the upper left part of the control panel, and indicates the engine water temperature.
- **Tachometer**-----It's between the water temperature indicator and the turning indicator. It indicates the engine rotative speed.
- **Turning Indicator** -----It's on the right of the tachometer. It indicates the directional turning of your vehicle.



Right Part-----eight switches (from left to right)

- **Turning Light Switch** ----- Turn on this switch, then when you turn your vehicle, the turning light will turn on automatically to show the turning direction.
- **Master Light Switch**-----It controls all the light switches.
- **Position Light Switch**-----Turn on this switch, and then the position light will show you the position of your vehicle.
- **Headlight Transform Switch**-----It can transform the high beam headlight to the dipped headlight, or the dipped headlight to the high beam headlight.
- **Emergency Warning Light Switch**-----Turn on this switch, then once your vehicle is in any emergency, the emergency warning light will turn on automatically to warn you against it.
- **Horn Switch**-----Turn on this switch, then you can sound your horn whenever necessary.
- **Emergency Stop Switch**-----In case your vehicle comes across some emergency in traveling, and you need to stop the engine immediately, you can use this switch.
- **Key Switch**-----Insert the key into the key switch, turn the key clockwise, and release the key when the engine starts. The engine will warm up within 5 minutes, and the engine choke will close automatically and operate at formal RPM.

Warning: Don't crank the starter more than 5 seconds at one time.

d. Engine Stop Button

Important-----the Engine Stop Button test. Before driving your **Buggy**, test the Engine Stop Button to assure that it is operating properly. When the engine is running, move the Stop Button to the “OFF” position.

B. Pre-Drive Inspection



- **Perform this pre-drive inspection every time before driving your vehicle.**
- **If not, serious damages to your vehicle or personal injuries to yourself may be caused.**

- Engine Oil:* Check for the engine oil level, and add oil if required; check for oil leaks; don't let any water go into the engine, otherwise the engine can't start;
- Fuel:* Check for the fuel level, and add fuel if necessary (but don't overfill); check for fuel leaks.
- Brakes:* Depress the rear brake pedal several times to see if it works properly, and check for the proper free play of brake pedal; adjust the brake pedal if necessary. Make sure there is no brake fluid leakage.
- Tires:* Check the tire conditions and pressures.
- Drive Chain:* Check for the chain conditions and tension; lubricate it if necessary.
- Throttle:* Check for the smooth operation; assure that the throttle "snaps" back to the idle position.
- Engine Stop Button:* Perform the engine stop button test; repair it if necessary.

- h. *Nuts, Bolts & Fasteners*: Check all the nuts, bolts and other fasteners to see if they have been tightened to the specified condition; adjust them if necessary.
- i. *Roll Cage Bar*: Ensure that all the protective roll cage bars are in place.
- j. *Brake Light*: Check for the proper operation of brake light.
- k. *Wheels*: Check the wheels to see if all the axle nuts have been tightened properly and been secured by cotter pins.
- l. *Steering*: Check for the free operation of the steering and for any unusual looseness in any area.
- m. *Lights*: Check the headlights, turning lights, rear license lights and taillights etc. for proper work.
- n. *Horn*: Make sure that the horn works properly.
- O. *Cooling System*: check if the cooling system can work properly after the engine has started.

 **WARNING**

- **Always follow rules for safe operation.**
- **Always wear a helmet.**

Locations of Parts:

Double-Seat





Single-Seat



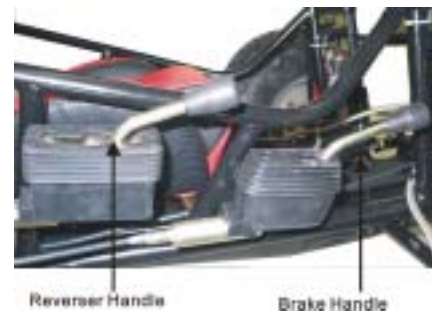
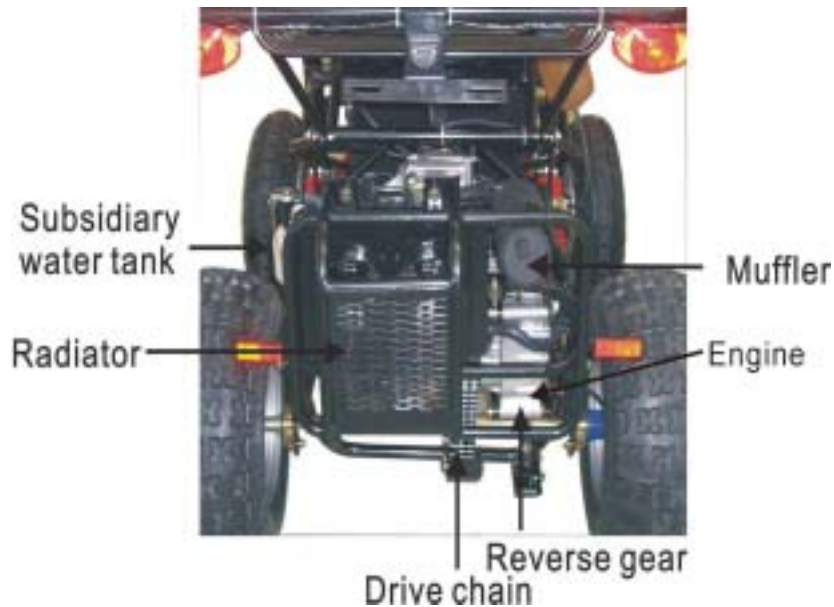

C. Preparations before Starting the Engine

- (1) Check the engine fasteners before starting;
- (2) Fill in the fuel, lubrication oil and anticorrosive antifreeze as specified;
 - a. Oil Capacity & Anticorrosive Antifreeze Capacity:
 - a) Oil Capacity: Crankcase: 1.0 L;
Transmission Box: 0.2 L;
 - b) Anticorrosive Antifreeze Capacity:
Radiator: 750cc;
Reserved Water Tank: 300cc;
Total: 1050cc;
 - b. Way of Adding the Anticorrosive Antifreeze:
 - a) Remove the radiator cover, and add the antifreeze up to the top of the radiator;
 - b) Fasten the radiator cover;
 - c) Start the vehicle;
 - d) Stop the vehicle when the water temperature reaches 80°C;
 - e) Open the radiator cover 5 minutes after stopping the engine, fill in the cooling fluid up to the top of the radiator, and. fasten the radiator cover;
 - f) Repeat c), d) and e) steps to re-add the cooling fluid for the third time. The total quantity of the

antifreeze added is 1190cc;

- g) Remove the spark plug and check the sparkle.

⚠ WARNING

- **Don't open the water tank cap when the engine temperature is high. Otherwise, the jetting of the hot water may cause injuries**

D. Passengers

The vehicle allows for two riders only for the double-seat unit and one rider only for the single-seat unit. The combined maximum weight of the driver and passenger for the double-seat unit should not exceed 180kg or 400lbs; the combined maximum weight of the driver and passenger for the single-seat unit should not exceed 90kg or 200lbs.

E. Seat Adjustment

The seat must always be securely fastened in the position which affords the best control of the foot pedals, steering wheel and engine stop button for the operator.

- a. Pull the seat adjustment handle upward to disengage the seat



slide;

- b. Move the seat to a desired position;
- c. Be sure that the seat adjustment handle snaps back into place and that the seat is locked into position.

 **WARNING**

- **Before attempting to adjust the seat, ensure that the engine of your RAIDER MAX 175 has stopped.**

 **WARNING**

- **Never operate your BUGGY when the provided seat is not securely fastened. Otherwise, it could result in a strong possibility of severe personal injuries or loss of life.**
- **Before attempting to adjust the seat, ensure that the engine of your BUGGY has stopped.**

F. Starting and Operating Instructions

- a. Before starting the engine, be sure that you've properly sat in your vehicle and tightened the seat belt;
- b. Test your vehicle in the beginning to learn how to start, turn and stop;
- c. Operate your vehicle slowly until you've been familiar with it;
- d. The turning radius of your vehicle is small and agile, so the centrifugal force is very high when turning at

high speed. You'd better slow down to a more controllable speed to prevent your vehicle from rolling over;

- e. To prevent your vehicle from rolling over when turning, be sure to only turn your vehicle at a more controllable slow speed and to keep your heel on the ramp of the main board. If you keep your legs on the foot pedals, you can feel the vehicle is stable because the gravity is adjusted. So your vehicle won't roll over.

G. Starting the Engine

- (1) Check if the fuel line is smooth;
- (2) Check if the ignition system is working properly;
- (3) Press the starting button when the throttle is closed;
- (4) Warm up the engine for 2-3 minutes after starting the cold engine.

Note:

- (1) Release the starting button and cut the power of the starting motor immediately after starting the engine;
- (2) Don't press the starting button after starting the engine. Otherwise, it may cause damages to the engine;
- (3) Don't press the starting button for more than 3-4 seconds for one time; wait for about 10 seconds to repress, and press the button with the throttle slightly opened;

- (4) In cold weather, warm up the engine for several minutes at the idle speed; then speed up once the operation temperature has reached the requirements specified;
- (5) In hot weather, avoid running the engine at the idle speed for a long time; otherwise, it may overheat the engine.

H. Stopping the Engine

- (1) Run the engine for about 3-5 minutes at the idle speed to cool down;
- (2) Turn off the throttle;
- (3) Turn off the ignition switch.

I. Running-In of the New Engine

The running-in distance is 1000km. During this period, please follow the instructions below:

- (1) Run the engine according to the requirements specified;
- (2) Rotate the throttle slowly after starting the engine; don't speed up or speed down suddenly;
- (3) Drive on smooth roads; don't drive uphill or on rough roads for a long time;
- (4) Keep the oil lines smooth;
- (5) Avoid speeding up suddenly or running the engine at a high speed without loading;
- (6) Maintain your vehicle according to the service intervals, and if necessary, repair it as soon as possible;

- (7) After the running-in period, clean the crankcase and replace the oil; remove the carbon on the top of the piston and in the combustion chamber; adjust the spark plug electrode gap and valve clearance; check if the oil lines are smooth; maintain your whole vehicle according to the requirements specified in this Owner's Manual.

SERVICE INSTRUCTIONS

A. Air Cleaner

Service the air cleaner every 20 hours of usage.

Note: Service more often when running under dusty conditions.

- a. Remove the air cleaner cover;
- b. Remove the air cleaner element;
- c. Fill the non-flammable cleaning agent into a basin and dip the element in it;
- d. Dry it after cleaning, and dip it into the engine oil specified by the manufacturer, then dry it again.

B. Spark Plug

- a. Remove the spark plug and inspect it with a spark plug wrench each time you change the oil;

Note: The electrodes should be kept clean and free of carbon. The presence of carbon or excess oil will greatly reduce the proper engine performance.



If possible, check the spark plug gap (area between the electrodes) with a wire feeler gauge. This specification is 0.6-0.7mm.

- b. Before installing the spark plug, coat the threads lightly with the graphite grease if possible, to ensure the easy removal next time when the spark plug needs inspection;
- c. It is advisable to replace the spark plug at least once a year to insure the easy starting and good engine performance.

C. Carburetor Adjustment

Never make unnecessary adjustments. The manufacturer recommended settings are correct for most applications. It's not necessary to disassemble the screw unless the carburetor needs to be replaced. Prepare a 50r/w tachometer before the adjustment.

- a. Warm up the engine for about 5~10 minutes;
- b. Tighten the airscrew gently and back out 2-3/8 turns anticlockwise;
- c. Connect the tachometer, and adjust the throttle to limit the idle speed (the standard value is 1700 RPM);



- d. Slowly turn the airscrew anticlockwise; observe the RPM of the engine, and stop the adjusting as the RPM reaches the top speed;
- e. Adjust the screw, and adjust the idle speed to an ideal value;
- f. Repeat the steps d and e until the rotate speed of the engine becomes stable.

D. Cleaning Instructions

Keep your vehicle clean. Use a clean rag to wipe off the dirt and oil from around the controls, and wipe off any spilled fuel and oil. Keep the engine clean of foreign objects and be sure that the water tank fan is free of debris for proper cooling.

E. Vehicle Lubrication

Lubricate your vehicle every 90 days of use. Apply several drops of oil in the specific points.

F. Chain Lubrication

Fill a spray atomizer with the specified chain lubrication, and lubricate the chain.

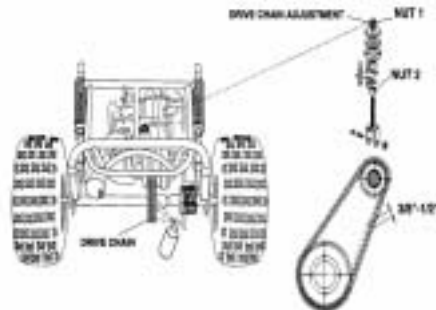

G. Chain Adjustment

Check the chain adjustment after the first two hours of use, and readjust the chain if it has more than 1/2" flex.

- a. Loosen Nut # 1;
- b. Turn Nut # 2 clockwise in 1/2-turn increments, then turn nut # 1 until it is tightened;
- c. Repeat the two steps a, b until the chain is adjusted to the desired tension.

H. Adjustment of Front Shock

There are five adjustable positions on each shock. The default position is in the middle set by the manufacturer.

Use a round nut wrench as you adjust the shock. The tension of the shock spring will increase as you screw to the left and decrease as you screw to the right.



I. Storage Instructions

In the event your vehicle isn't to be operated for periods in excess of 30 days or at the end of each driving

season, prepare for the storage as follows:

- a. Drain (or use a fuel stabilizer) all the fuel out of the fuel tank and carburetor;
- b. Remove the spark plug; pour one ounce of clean cylinder lubricating oil through the spark plug hole into the cylinder, and crank the engine slowly to spread the oil so as to lubricate the cylinder better; replace the spark plug;
- c. Don't save or store gasoline over winter, because the old gasoline has deteriorated in the winter storage, and will cause hard starting and affect the engine performance.

WARNING

- **Don't drain the fuel while the engine is hot.**
- **Be sure to move your BUGGY outside before draining the fuel.**

J. Engine Maintenance

(1) Daily Maintenance:

- a) Remove the dust and dirt on the surface;
- b) Check all the exterior fasteners at the joints, and fasten or replace them if necessary;
- c) Check for the oil leakage, and check the

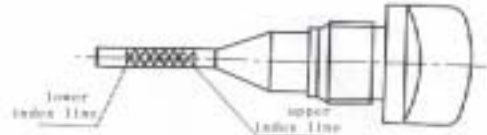

compression at the mating surface;

- d) Check the engine oil, and add some if necessary.

Note: The oil level should be between the upper index line and the lower index line of the gauge.

(2) 50–Hour Maintenance:

- a) Finish the daily maintenance;
- b) Remove the dust in the air cleaner element; replace the element if there is too much dust or any damp;

Note: Don't dip the element in water or oil. Don't apply any lubrication oil or any other oil on the element. Otherwise it may cause damages to the transmission belt.

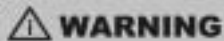

- **Don't clean the element with gasoline or solvent of low flash point.**

- c) Remove the carbon on the spark plug;
- d) Clean the crankcase and replace the oil;
- e) Clean the transmission box and replace the gear oil;
- Remove the cap ②;
 - Remove the filling bolt ①;

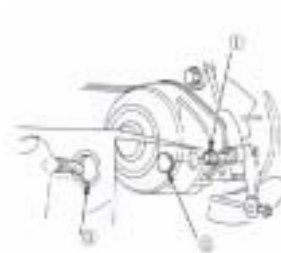

- Remove the drain bolt ③;

Note: When draining the oil, the engine should be at some temperature, which can ensure the quick and complete draining.

f) Check the cooling devices.

- Check for the leakage of the water tank and water pipe;
- Check if the water in the subsidiary water tank is between the upper limit ① and lower limit ③;
- If the water is insufficient, please open the cap ② and add some water until the water level reaches the upper limit ①.



(3) 100-Hour Maintenance:

- a) Finish the 50-hour maintenance;
- b) Remove the cylinder cover and cylinder body, and clean out the carbon on the cylinder cover, cylinder body, piston top and in/ex valve, etc.;
- c) Clean the inner part of the crankcase, and rotate the crankshaft during the cleaning to clean the main bearing and connecting rod big end needle bearing;
- d) Check if the fixed screw of the generator stator is loose;

- e) Keep the connectors and electric parts dry and clean.
- (4) 150-Hour Maintenance:
- a) Finish 100-hour maintenance;
 - b) Clean the crankcase and replace oil;
 - c) Check if there is any leakage on the oil seals; replace the oil seals if necessary.
- (5) 300-Hour Maintenance:
- a) Finish 150-hour maintenance;
 - b) Check if the parts of the clutch and the transmission are normal; adjust or replace the parts if necessary.
- (6) 500-Hour Maintenance:
- a) Finish 300-hour maintenance;
 - b) Disassemble the engine (except the crankshaft connecting rod); check the parts for wear, and repair or replace the parts if necessary;
 - c) Replace the cooling fluid.

REPAIRS

A. Front Wheels Replacement

Don't disassemble the castle nuts when replacing the front wheels.

It is only necessary to tighten the nuts so that the wheels turn freely on the axle with minimum endplay. Tighten the nuts after replacing the wheels.

B. Rear Wheel Replacement

Don't disassemble the castle nuts when replacing the rear wheels.

It is only necessary to tighten the nuts so that the wheels turn freely on the axle with minimum endplay. Tighten the nuts and put on the cotter pins after replacing the wheels.

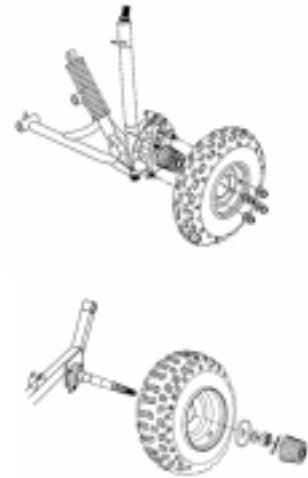

PERIODICAL CHECK AND SERVICE

The maintenance intervals in the following table are based upon average riding conditions. Riding in unusually dusty areas requires more frequent services.

Items	First week	Monthly	Quarterly	Yearly
Tire pressure/wear, Brake performance, Tightness of screws	I	I		
Air cleaner		C	C	I
Carburetor	I	A		C
Spark plug			C, A	
Drive chain	I	I	C, A, L	
Brake fluid			I	
Replace gearbox oil		I	R	
Chassis		C, I	L	
Fuel switch/fuel tank				C
Battery	I		I	
Engine oil		R		
Valve clearance of engine			A	

Note: A: adjust; C: clean; I: inspect, clean or replace if necessary; L: lubricate; R: replace.

OPTIONAL PARTS**Mudguard Assembly Instructions****1. Assemble left front mudguard**

- a) Install the left support of the front mudguard and the front mudguard by using 4 Flange bolts (convex) M6×16, 4 Flange nuts M6, 4 washers ϕ 6 and 4 spring washers ϕ 6;



- b) Fix the left support of the front mudguard and the left knuckle support by using 4 socket-head bolts

M8×25, 4 hex nuts M8 and 4 spring washers ϕ 8.

2. Assemble right front mudguard



- a) Install the right support of the front mudguard and the front mudguard by using 4 Flange bolts (convex) M6×16, 4 Flange nuts M6, 4 washers ϕ 6 and 4 spring washers ϕ 6;



A2

A1

- b) Fix the right support of the front mudguard and the right knuckle support by using 4 socket-head bolts M8×25, 4 hex nuts M8 and 4 spring washers ϕ 8.

3. Assemble left rear mudguard



- a) Install the left support of the rear mudguard and the rear mudguard by using 4 Flange bolts (convex) M6×16, 4 Flange nuts M6, 4 washers ϕ 6 and 4 spring washers ϕ 6;



B1

B2



- b) Fix the left support of the rear mudguard and the left pipe of the rear swing arm by using 4 Flange bolts (convex) M8×50, 4 hex nuts M8 and 4 spring washers ϕ 8.

4. Assemble right rear mudguard



- a) Install the right support of the rear mudguard and the rear mudguard by using 4 Flange bolts (convex) M6×16, 4 Flange nuts M6, 4 washers ϕ 6 and 4 spring washers ϕ 6;



- b) Fix the right support of the rear mudguard and the right pipe of the rear swing arm by using 4 Flange bolts (convex) M8×50, 4 hex nuts M8 and 4 spring washers $\phi 8$.

5. Mudguard and Bracket

- a) A1: Mudguard Bracket Outer, Front
- b) A2: Mudguard Bracket Inner, Front
- c) B1: Mudguard Bracket Outer, Rear
- d) B2: Mudguard Bracket Inner, Rear



A1

A2

Mudguard and Front Bracket



B1

B2

Mudguard and Rear Bracket

SPECIFICATIONS**DIMENSIONS****SINGLE-SEAT/ DOUBLE-SEAT**

Overall Length	2330mm / 2300mm
Overall Width	1310mm / 1460mm
Overall Height	1425mm / 1425mm
Wheelbase	1475mm / 1520mm
Ground Clearance	200mm / 250mm
VIN	accord with GMVR A01-01
Statutory Plate& Safety Labels	accord with GB 7258-1997

ENGINE

Model	PMI162MK
Type	Forced Water-cooled, Single Cylinder, 4-stroke
Engine Capacity	175cc
Displacement	174.5ml
Bore×Stroke	62mm×57.8mm
Max. Power	7.4kw or 7500rpm
Max. Torque	12.5N.m or 6500 rpm

Idle Speed	1500±100rpm
Idle Speed CO Emission	7.0g/km
Idle Speed HC Emission	1.0 g/km
Fuel Type	SAE 90# or Above (Unleaded)
Min. Fuel Consumption	354g/KW.h
Lubricate Oil Type	SAE 10W / 30SF
Lubrication	Pressure & Splash
Cooling Fluid	Anti-corrosive, Anti-freeze
Cooling	Water-cooled
Ignition	C.D.I.
Starting	Electric
Spark Plug	D7
Spark Plug Gap	0.6-0.7mm
Transmission	Chain Transmission
Transmission Ratio	F 1:1, B 1:1.758
Primary Transmission Ratio	2.2-0.9
Compression Ratio	10±0.1: 1
Reduction Ratio	2.8

Clutch	Automatic, Centrifugal, Dry, Shoe Type
Generator	Outer Rotor, Flywheel
Carburetor	Vacuum Film Type
Absorber	Normal (in $10^6 \times 10^4$ times of experiments)
Air Cleaner	Paper Element, Filtration Type
Gear-Shifting	Automatic, Centrifugal

CAPACITIES

Front/Rear Tire Load	36
Front/Rear Tire Speed Level	L
Fuel Tank	7.0L, 130kpa (no leakage in experiments)
Starting Time	$\leq 15s$
Climbing	$\geq 20\%$
Top speed	63kmph
Tachometer	33-40kmph
Turning Radius	3m/3.5m
Acceleration Noise Level	$\leq 80dB (A)$
Horn	DL80-90 12V 3A 105Db, 93<db (A) <112

Headlight	12V 35W/35W
Headlight High Beam Intensity	regulations/law-oriented
Taillight	12V 5W /21W
Turning Light	12V 10W
License Light	12V 5W
Battery	12V 8Ah
Anti-theft Lock	$\geq 200\text{N} \cdot \text{m}$
Rearview Mirror	accord with EEC standards

CHASSIS

Front/Rear Brake	Hydraulic Disc, Foot Control
Front Wheel Brake Force	760N/1140N
Rear Wheel Brake Force	832N/1038N
Braking Distance	$\leq 7 \text{ m}@30\text{kmph}$
Parking Brake	Hydraulic Disc, Hand Control
Front Tire	21 X 7 –10
Rear Tire	22 X 11 –10

TIRE PRESSURE

Front 175kpa

Rear 200kpa

WEIGHT

Net Weight 235kg / 255kg

Wiring Diagram

