

DAZON



# SERVICE MANUAL

**Raider Max 175-S  
&  
Raider Max 175-D**

(EEC APPROVED FOR ON ROAD USE)



## FOREWORD

This service manual has been specially prepared to provide all the necessary information for the proper maintenance and repair of the **RAIDER Max 175 (EEC-approved for on-road use)**.

The **Buggy** fits the needs of a wide variety of buggy users above 16 years old. Those who will service this **Buggy** should carefully review this manual before performing any repair or service.

All information, illustrations, photographs and specifications contained in this manual are based on the latest product information available at the time of publication. Due to the improvements or other changes, there may be some discrepancies in this manual. Therefore, if the newest information is requested in future, please contact the local distributor.

Distributors reserve the right to make production changes at any time, without prior notice or incurring any obligation to make the same or similar changes for the vehicles previously built or sold.

# CONTENTS

- 1. General Information -----4**
- 2. Periodic Maintenance and Tune-Up Procedures -----7**
- 3. Engine -----13**
  - 3.1 Lubrication System-----13**
  - 3.2 Cylinder Head & Valve-----15**
  - 3.3 Drive Pulley, Clutch & Driven Pulley-----16**
  - 3.4 Final Transmission Box-----17**
  - 3.5 Ac Generator & Starting Clutch-----18**
  - 3.6 Crankcase & Crankshaft-----19**
  - 3.7 Cooling System-----20**
  - 3.8 Carburetor-----24**
- 4 Wiring Diagram -----29**

## 1. General Information

### 1.1 Model Identification

#### 1.1.1 Frame Number

The frame number or VIN is stamped under the seat on the frame and stuck behind the seat.

#### 1.1.2 Engine Number

The engine number is located on the upper rear right engine case.



### 1.2 Fuel and Oil Recommendations

Be sure to use the specified fuel and oil

#### 1.2.1 Fuel

Please use the gasoline of SAE 90# or above.

Also we recommend you to use the unleaded gasoline.

#### 1.2.2 Engine Oil

Please use the high-quality engine oil of SAE 10w/30SF.

### 1.3 Break-in Procedure

For your first 2 hours of riding, don't exceed 2/3 throttles.

Vary the engine speed for the first 5 hours.

Never hold the engine at full throttle for long periods of time.

## 1.4 Specifications

### DIMENSIONS

Overall Length	2330mm / 2300mm
Overall Width	1310mm / 1460mm
Overall Height	1425mm / 1425mm
Wheelbase	1475mm / 1520mm
Ground Clearance	200mm / 250mm
VIN	accord with GMVR A01-01
Statutory Plate & Safety Labels	accord with GB 7258-1997

### SINGLE-SEAT/ DOUBLE-SEAT

### ENGINE

Model	PMI162MK
Type	Forced Water-cooled, Single Cylinder, 4-stroke
Engine Capacity	175cc
Displacement	174.5ml
Bore × Stroke	62mm × 57.8mm
Max. Power	8.0kw or 7000rpm
Max. Torque	12.0N.m or 5500 rpm
Idle Speed	1500±100rpm
Idle Speed CO Emission	≤3.8%
Idle Speed HC Emission	≤800 ppm
Fuel Type	SAE 90# or Above (Unleaded)
Min. Fuel Consumption	354g/KW.h
Lubricate Oil Type	SAE 10W / 30SF
Lubrication	Pressure & Splash
Cooling Fluid	Anti-corrosive, Anti-freeze
Cooling	Water-cooled
Ignition	C.D.I.
Starting	Electric
Spark Plug	D7
Spark Plug Gap	0.6-0.7mm
Transmission	Chain Transmission
Transmission Ratio	(forward) 1:1, (backward) 1:1.758
Primary Transmission Ratio	2.2-0.9
Compression Ratio	10.0 : 1
Reduction Ratio	2.8
Clutch	Automatic, Centrifugal, Dry, Shoe Type
Generator	Outer Rotor, Flywheel
Carburetor	Vacuum Film Type
Absorber	normal (in 10 <sup>6</sup> X10 <sup>4</sup> times of experiments)
Air Cleaner	Paper Element, Filtration Type
Gear-Shifting	Automatic, Centrifugal
Engine Size	422mm × 430mm × 527mm

Engine Net Weight 31.5 kg

### **CAPACITIES**

Fuel Tank 7.0L, 130kpa (no leakage in experiments)  
 Starting Time 15s  
 Climbing 20%  
 Top speed 70kmph  
 Tachometer 33-40kmph  
 Turning Radius 3m/3.5m  
 Acceleration Noise Level custom-engineered  
 Horn 12V 3A 105dB  
 Headlight 12V 35W/35W  
 Taillight 12V5W /21W  
 Battery 12V 8Ah

### **CHASSIS**

Front/Rear Brake Hydraulic disc, foot control  
 Front Wheel Brake Force 760N/1140N  
 Rear Wheel Brake Force 832N/1038N  
 Braking Distance 7 m@30kmph  
 Parking Brake Hydraulic disc, hand control  
 Front Tire 21 X 7 –10  
 Rear Tire 22 X 11 –10

### **TIRE PRESSURE**

Front 175kpa  
 Rear 200kpa

### **WEIGHT**

Net Weight 235kg / 255kg

- The specifications are subject to change without notice.

## 2. Periodic Maintenance and Tune –up Procedures

### 2.1 Location of Parts

#### Double-seat

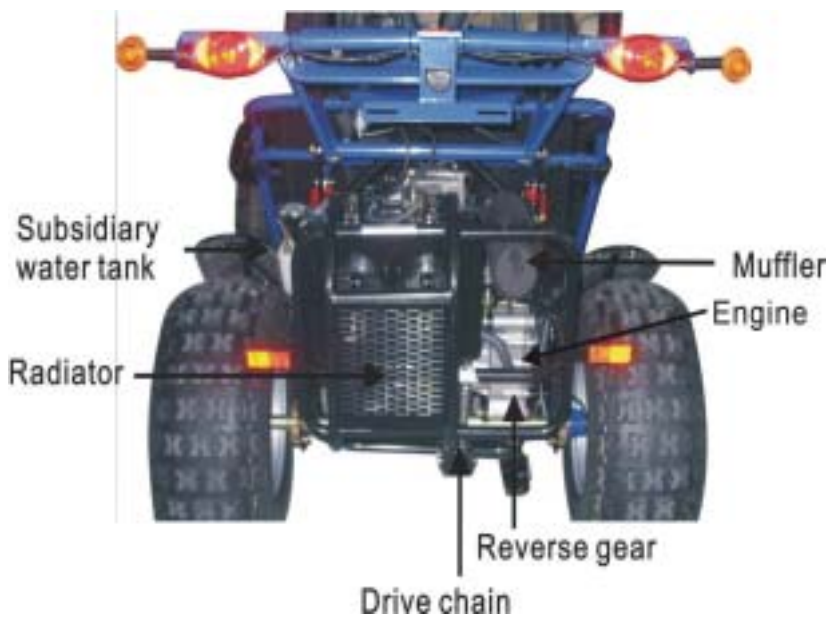

### Single-seat

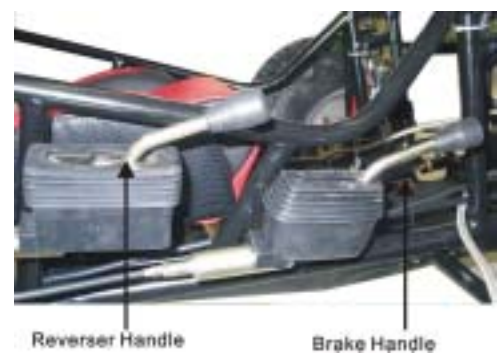

\* Please demand for a copy of the Parts Book from your dealer and locate each component location.

## 2.2 Periodical Checks and Services

The maintenance intervals in the following table are based upon average riding conditions. Riding in unusually dusty areas requires more frequent services.

Items \ Time of Service	Initial Service (First Week)	Monthly	Quarterly	Yearly
Tire Pressure/Wear	I	I		
Brake Performance	I	I		
Bolt Tightness	I	I		
Air Cleaner		C	C	I
Carburetor	I	A		C
Spark Plug			C, A	
Drive Chain	I	I	C, A, L	
Brake Fluid			I	
Replacement Of Gearbox Oil		I	R	
Chassis		C, I	L	
Fuel Switch/Fuel Tank				C
Chassis	I		I	
Engine Oil		R		
Valve Clearance Of Engine			A	

**Notes:** A: Adjust; C: clean; I: inspect, clean or replace if necessary; L: lubricate; R: replace.

## 2.3 Maintenance and Tune-up Procedures

This section describes the servicing procedures of every item in the Periodic Maintenance Intervals Table above.

### 2.3.1 Spark Plug

Clear up the carbon around the spark plug to prevent it from dripping into the cylinder when removing the spark plug.

Remove the spark plug:

- In general, it should be carried on after the engine has cooled down;
- If the spark plug is too tight to remove, spray some rust inhibitor on the spark plug washer and the thread part; after the inhibitor has soaked the washer and thread part, rotate the spark plug;
- Clear up the filth and carbon accumulation on the spark plug with a steel brush or a blade;



- d) Inspect the spark plug gap (in general, it should be about 0.6 - 0.7 mm.);
- e) When the carbon accumulation and wear of the spark plug are too serious, replace the spark plug with a new one of the same specification.

### 2.3.2 Tire Pressure / Wear

Check the tire pressure before each of your driving.

The tire pressure is very important for the riding stability.

Specifications: Front Tire: 175kpa

Rear Tire: 200kpa

### 2.3.3 Brake Performance

- a) Always check if there is plenty of brake fluid in the brake fluid reservoir;
- b) Check if the front/rear brake pad is in good condition;
- c) Check the brake rotor for abnormal wear.



### 2.3.4 Air Cleaner

Clean the air cleaner quarterly, or more often when driving in dusty conditions.

If the air cleaner is clogged with dust, its performance will be severely decreased, even the engine damages will probably be caused.



### Inspection and Cleaning of Filters

#### ● Paper Filter

- a) Remove the filter from its housing;
- b) Lightly tap the filter on an object to knock out the dust;
- c) Replace the filter element if it is wrinkled or torn.

#### ● Foam Filter

- a) Remove the filter out of its steel cage;
- b) Wash the filter in non-flammable cleaning solvent;
- c) Submerge the filter in oil and squeeze it to remove excess oil;
- d) Install the filter element back into the air box.

### CAUTION

- Before and during the cleaning, inspect the element for tears; replace it if it's torn.
- Make sure that the element is seated properly and no foreign material can pass by it

### 2.3.5 Nuts and Bolts in Chassis

Inspect the nuts and bolts in the chassis during the first week and every month thereafter.

The nuts and bolts become loose normally after use, please check for the looseness regularly.

### 2.3.6 Tightening Torque Table

Bolt Diameter (mm)	Conventional Marked Bolt			8.8 Marked Bolt		
	N•m	Kg•m	lb-ft	N•m	Kg•m	lb-ft
4	1-2	0.1-0.2	0.7-1.5	1.5-3	0.15-0.3	1.0-2.0
5	1-4	0.2-0.4	1.5-3.0	3-6	0.3-0.6	2.0-4.5
6	4-7	0.4-0.7	3.0-5.0	8-12	0.8-1.2	6.0-8.5
8	10-16	1.0-1.6	7.0-11.5	18-28	1.8-2.8	13.0-20.0
10	22-35	2.2-3.5	16.0-25.5	40-60	4.0-6.0	29.0-43.5
12	35-55	3.5-5.5	25.5-40.0	70-100	7.0-10.0	50.5-72.5
14	50-80	5.0-8.0	36.5-58.0	110-160	11.0-16.0	79.5-115.5
16	80-130	8.0-13.0	58.0-94.0	170-250	17.0-25.0	123.0-181.0
18	130-190	13.0-19.0	94.0-137.5	200-280	20.0-28.0	144.5-202.5

### 2.3.7 Fuel Switch Inspection

- Stop the engine, remove the gasoline tube from the carburetor, and check if the gasoline is flowing;
- After expelling the gasoline remnant (about 5-10 ml) from the negative pressure switch and negative pressure tube, if the gasoline doesn't flow, the switch is in good condition; otherwise, the negative pressure tube needs cleaning;
- Remove the negative pressure tube from the gasoline supply tube, and suck it with mouth or apply pressure on it with a vacuum pump, and then release the pressure;  
If the gasoline flows out of the gasoline tube when under pressure, and stops flowing when released from pressure, the switch is in good condition.

#### Note:

- Smoking and lighting fires are strictly forbidden.
- Before the operation, blow enough air from the supply side of the negative pressure switch, so as to eliminate the stuff sticking on the diaphragm.

### 2.3.8 Final Gear Oil

Inspect the final gear oil monthly and replace it quarterly.

- Check the oil level: remove the oil level screw on the left rear engine case;
- Drain out the oil: remove the drain plug at the rear bottom of the engine case;

Recommendation: before draining the final gear oil, please warm the engine for at least 10 minutes.



**Notes:**

We recommend the Mobile 85w/90 gear oil for the final drive case. However, in extreme cold weather conditions, the vehicle may become hard to start, so we advise some lighter viscous oil, such as 75 wt or the equivalent motorcycle transmission fluid.

Gear Oil Capacity	0.2L	85w/90
-------------------	------	--------

**2.3.9 Engine Oil**

Inspect the engine oil before every riding and replace it monthly. ■

- a) Remove the drain plug from the left side bottom of the engine, and drain out the left oil into an oil pan for disposal;
- b) Remove the large cap on the left bottom of the engine, and remove the screen;
- c) Wash the screen with some cleaning solvent and reassemble it; make sure that the O-ring is still in good conditions;
- d) Refill the engine with the SAE10W/30SF engine oil and run the engine for 5 minutes;
- e) Check the oil level on the filler cap stick to assure that it's proper;
- f) Screw in the large cap.

**2.3.10 Chassis**

Inspect, clean or replace it monthly if necessary and lubricate it quarterly.

- a) Grease the chassis bushings and bearings with some grease quarterly to make sure that they can operate smoothly and enjoy an extended life;
- b) If it's used in extremely wet, muddy or dusty conditions, we recommend you to service it more often.

## 3. Engine

### 3.1 Lubrication System

#### 3.1.1 Lubrication diagram

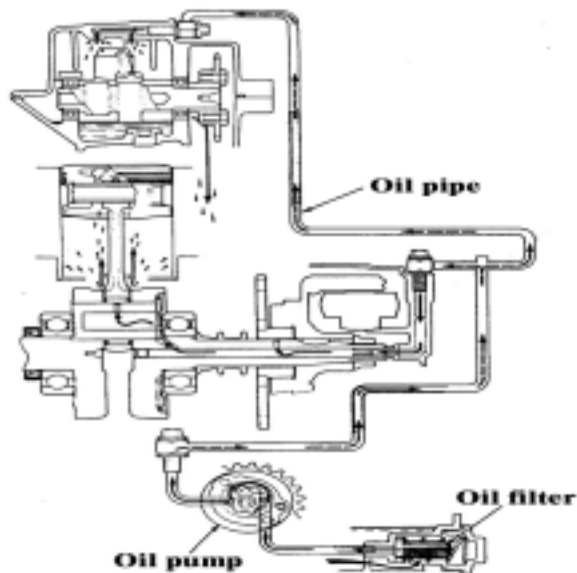

#### 3.1.2 Trouble shooting

- The engine oil level is too low.
  - a) The engine oil is consumed naturally;
  - b) The engine oil leaks;
  - c) The piston rings are worn.
  
- The engine oil is dirty.
  - a) The engine oil isn't replaced in time;
  - b) The cylinder head gasket is damaged.
  
- The lubrication isn't good.
  - a) The engine oil level is too low;
  - b) The oil filter is clogged, or the oil pipes are clogged;
  - c) The oil pump is damaged

#### 3.1.3 Specifications

Engine Oil Capacity	1.0L (Disassembling)	0.8L (Replacing)
Engine Oil	10W/30SF	

### 3.1.4 Engine Oil

#### ● Inspection

- Stop the engine;
- Stay the vehicle on the flat ground for 2-3 minutes;
- Inspect the oil level.

**Note:** The oil level gauge shouldn't be screwed in.



#### ● Replacement

- Remove the oil filler cover, and drain out the oil remnant when the engine is warm;
- Reassemble the cover;  
Torque: 18-20 N.m.
- Check if the O-rings are damaged; replace if necessary;
- Fill in the same type of engine oil;

Engine oil capacity: 1.0 L (Disassembling)  
0.8L (Replacing)

Engine oil type: 10W/30SF

- Start the engine to check if there is any oil leakage;
- Stop the engine and check the oil level again.



#### ● Engine Oil Screen

- Drain out the oil;
- Take out the spring filter;
- Assemble the screen, spring and filter cap;
- Add enough oil into the engine.

## 3.2 Cylinder Head & Valve

### 3.2.1 Disassembly Diagram

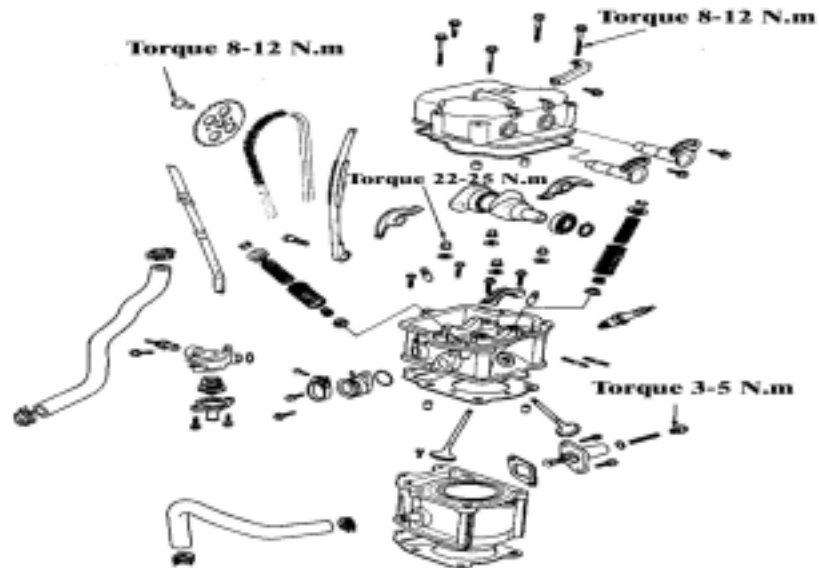

### 3.2.2 Trouble Shooting

- The compression is too low or not stable.
  - a) Valve
    - The lifter isn't adjusted well;
    - The valve is burnt or deformed;
    - The valve spring is damaged;
    - The valve timing is faulty;
    - The valve seat seal is faulty.
  - b) Cylinder Head
    - The cylinder head gasket leaks air;
    - The cylinder head is deformed or cracked.
  - c) Cylinder piston is faulty.
  
- The compression is too high.
  - There is carbon accumulation on the piston or in the combustion chamber.
  
- Noise
  - The lifter isn't adjusted well.
  - The valve is burnt, or the valve spring is damaged or worn.
  - The rocker or the rocker shaft is damaged or worn.

### 3.3 Drive Pulley, Clutch & Driven Pulley

#### 3.3.1 Disassembly Diagram

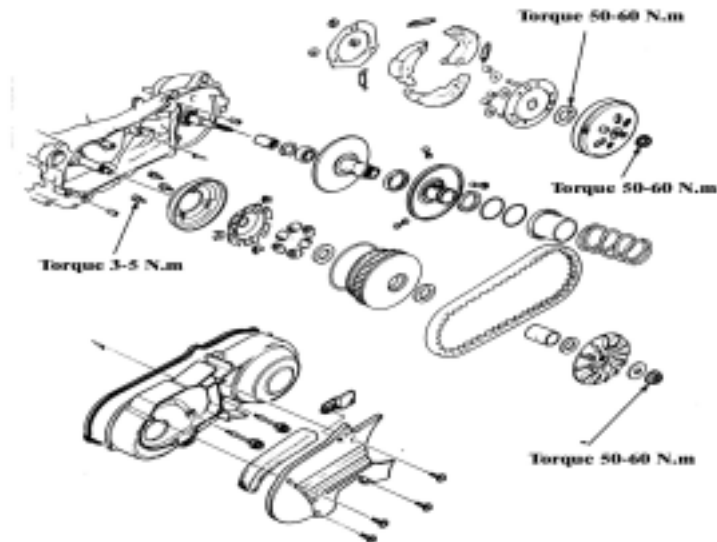

#### 3.3.2 Inspection of Drive Belt.

- a) Check if the belt is cracked and check if there is abnormal worn.
- b) Measure the width of the drive belt;  
Replace the belt if its width is below 17.5 mm

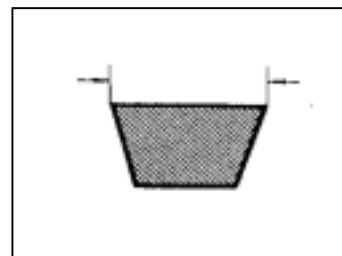

#### 3.3.3 Inspection of Clutch. Drive Surface

- a) Check if the clutch cover is worn or damaged;  
Measure the inner diameter;  
Replace the clutch if its inner diameter is above 130.5 mm.



- b) Check if the clutch shoes are worn or damaged;  
Measure the thickness.  
Replace the clutch shoes if the thickness is below 2.0 mm.



- c) Check the free length of the drive spring;  
Replace the spring if its free length is below 83.2 mm.

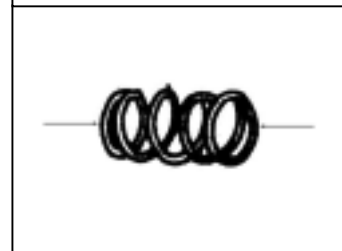

## 3.4 Final Transmission Box

### 3.4.1 Disassembly Diagram

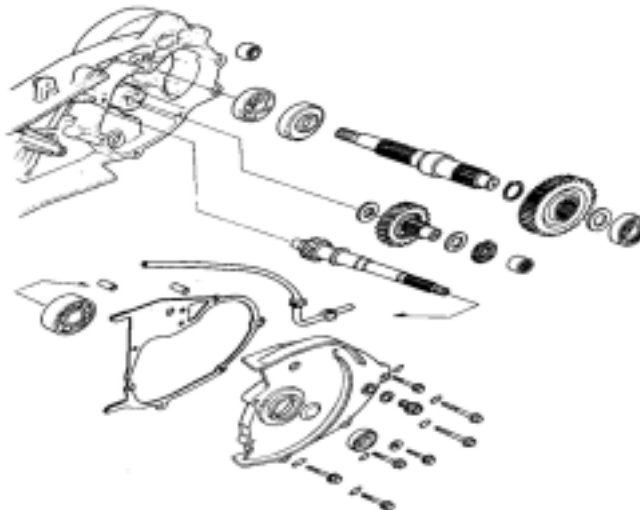

### 3.4.2 Final Transmission Box Oil

#### ● Inspection of Gear Oil Level.

- Stay the vehicle on the flat ground;
- Stop the engine and remove the oil level bolt;
- It is normal if the oil level parallels with the bolthole.

#### ● Replacement of Gear Oil.

Specifications: Oil Capacity: 0.2 L

Specified Gear Oil: Mobil 85w/90

Oil Level Bolt Torque: 14-18 N.m

- Check if there is any oil leakage after running the engine;
- Check the oil level again;
- Check if the oil seal is damaged;  
Replace it if necessary.



### 3.4.3 Trouble Shooting

- The engine can be started, but the vehicle can't run;
  - The gears are damaged;
  - The gears are burnt.
- There is noise when driving the vehicle.
  - The gears are worn or burnt, or the gear surface is damaged;
  - The bearing is worn or shaking.
- The oil leaks.
  - There is too much oil;
  - The oil seal is damaged or worn.

## 3.5 AC Generator & Starting Clutch

### 3.5.1 Disassembly Diagram

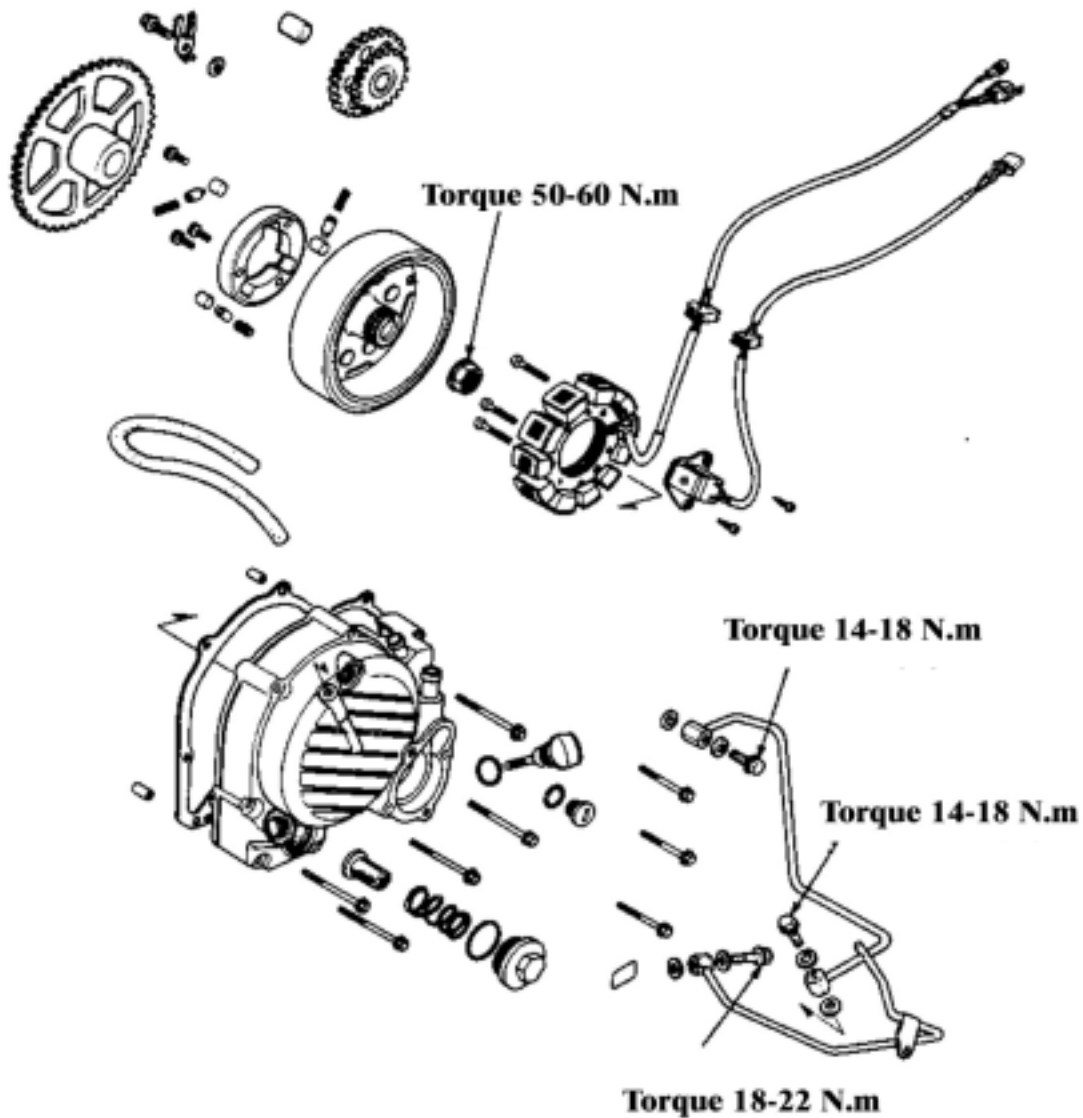

### 3.5.2 Trouble Shooting

- The AC generator is faulty.
- a) The starter reduction gear is faulty.
- b) The starter motor revolves conversely.
- c) The wires haven't been connected well.
- d) The starter clutch spring is broken, dirty or locked.

## 3.6 Crankcase & Crankshaft

### 3.6.1 Disassembly Diagram

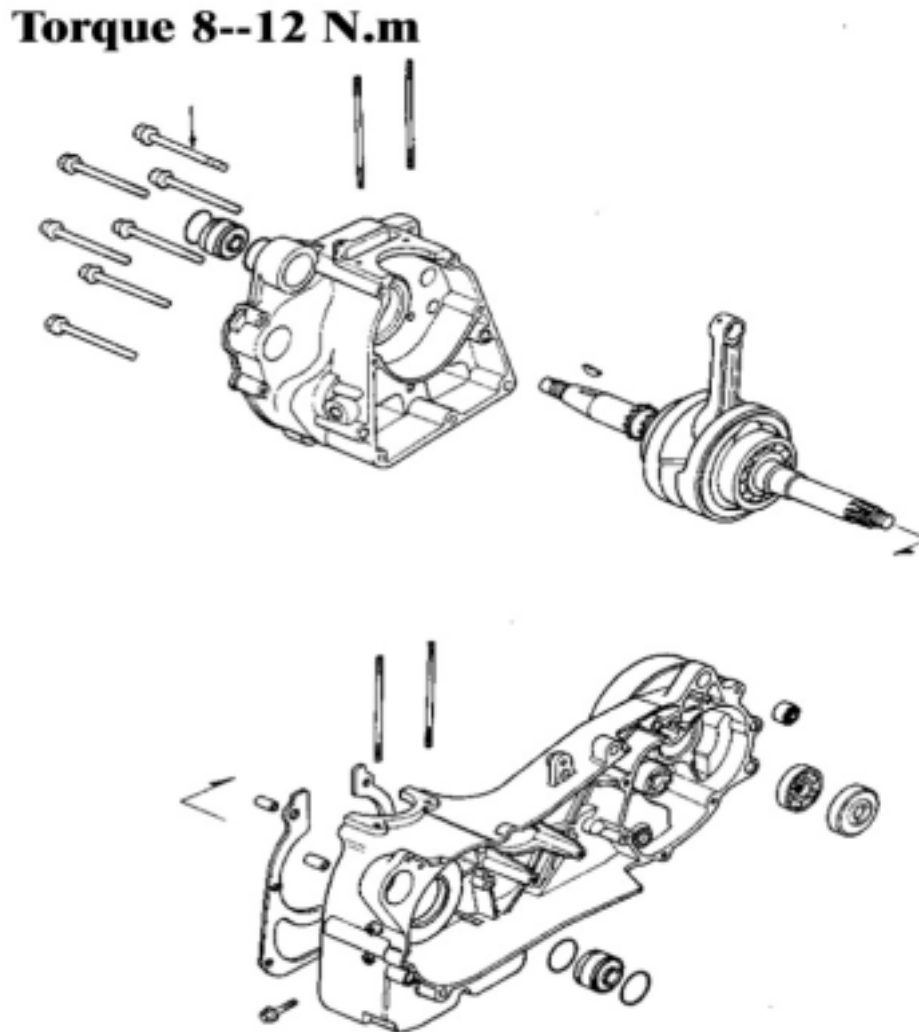

### 3.6.2 Trouble Shooting

- Engine noise
  - a) The bearing is loose.
  - b) The crankshaft pin bearing is loose.
  - c) The piston pin and the piston pin hole are loose.

## 3.7 Cooling System

### 3.7.1 Disassembly Diagram

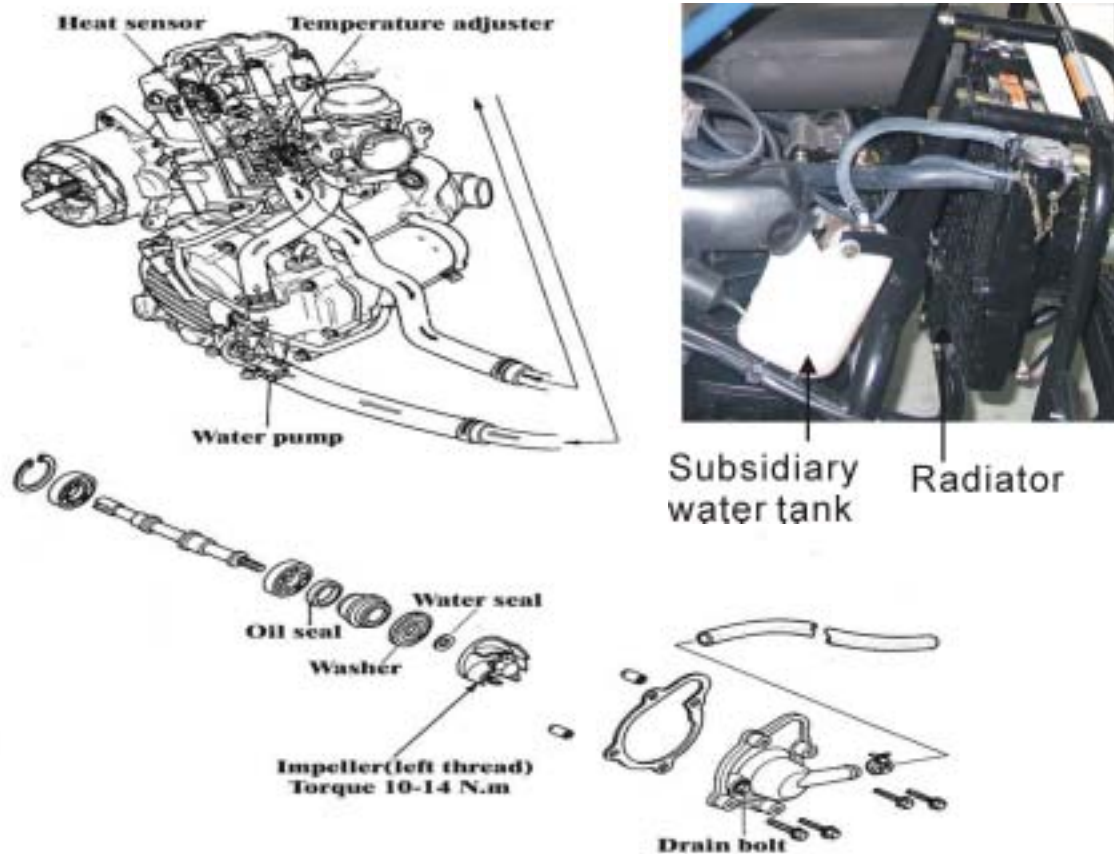

### 3.7.2 Trouble Shooting

- Water temperature rises.
  - a) The heat sensor of the thermometer is faulty.
  - b) The water tank cover is faulty.
  - c) The temperature petcock is faulty.
  - d) The tank fluid is insufficient.
  - e) The pump water pipe and water sleeve are clogged.
  - f) The radiator of the water tank is clogged.
  - g) The inner part of the water tank is clogged.
  - h) The water pump is faulty.
  
- The water temperature rises, but the thermometer doesn't show any signs of rising.
  - a) The heat sensor of the thermometer is faulty.
  - b) The temperature petcock is faulty.

### 3.7.3 Points for Attention

- The water pump repair and other operations of the cooling system can be carried out on the vehicle;
- Carry out the operations when the engine has cooled down;
- Don't open the water tank cover when the water temperature is above 100 °C ;
- Don't spread the water tank fluid onto the tank surface paint; if the fluid spreads out, clean up the fluid with water;
- After the inspections and repairs, use a water tank pressure tester to check all the joints and oil seals for leakage.

### 3.7.4 Specifications

Pressure of Water Tank Cover Petcock	0.9+/-0.15 Kg/Cm2	
Volume of Cooling Fluid	About 1450cc	Water Tank: 1100 Cc Subsidiary Water Tank: 350 Cc

**Notes:**

- a) Use the specified water tank fluid.
- b) Don't mix the fluid of different brands together.
- c) The water tank fluid is poisonous, please don't drink it.

### 3.7.5 Cooling System Pressure Test

- a) Check the water tank cover;
- b) Apply some water on the surface of the water tank cover oil seal , and install the water tank cover on the water tank tester;
- c) Apply the standard pressure on the water tank cover with the tester for about 6 seconds to check its stability.

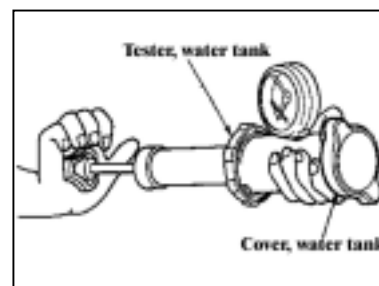

**Note:** Pressure for the opening and closing of the cover cock: 0.9+/-0.15kg/cm2.

- d) Check the water pipe joints for leakage.

**Note:** The test pressure shouldn't exceed 1.05kg/cm2; otherwise the joints of the water tank may be damaged.

### 3.7.6 Water Tank

- a) Check the water tank fluid level;
- b) Use the specified water tank fluid (standard concentration: 30%);

**Note:** The fluid level isn't affected by the engine temperature.

- c) Add some fluid up to "F" (the upper limit);
- d) Replace the fluid when the engine is cold;

Specifications: Water tank capacity: about 1100cc  
Subsidiary water tank: about 350cc

- e) Check if the welding seam of the radiator is damaged or leaking;



Radiator

- f) Clean the radiator plates if they are clogged or dirty;  
Repair if the radiator plates are deformed.

**3.7.7 Water Pump**

- a) Check the water seal of the water pump;  
Check the drain hole under the right crankcase cover for leakage;  
If there is any leakage, the water seal of the water pump is faulty;  
Remove the right crankcase cover and replace with a new water seal;



- b) Disassemble the water pump impeller;  
Remove the water pump impeller;



- c) Check the water seal and the water seal washer for damages and wear;  
Replace the water seal together with the water seal washer if necessary;

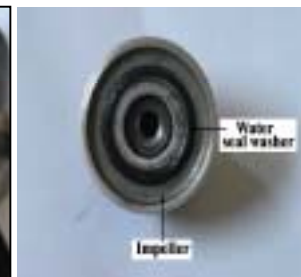

- d) Assemble the water pump shaft and the inner bearing into the right crankcase;  
Lock the bearing with the clip;



- e) Assemble the right crankcase cover;



- f) Assemble the water pump impeller;  
Replace the water pump water seal together with the impeller water seal if necessary;



g) Assemble the impeller pin on the shaft.

Torque: 10 N.m

**Note:** Fasten the impeller with the left thread.



h) Replace the water pump water seal;

Take out the water seal from the inside of the right crankcase cover;

Assemble a new water seal into the right crankcase cover;

**Note:**

Apply the water seal agent on the mating surface of the water seal and the right crankcase cover before assembly.



i) Assemble water pump shaft;

Assemble a new outer bearing of the water pump shaft inside the right crankcase cover.



### 3.7.8 Heat Sensor

● **Disassemble**

- a) Remove the rear side cover on the right;
- b) Drain out the water tank fluid;
- c) Disconnect the heat sensor wires;
- d) Remove the heat sensor.

● **Inspection**

- a) Put the heat sensor into the testing container;
- b) Raise the water temperature slowly;
- c) Measure the resistance value of the heat sensor.

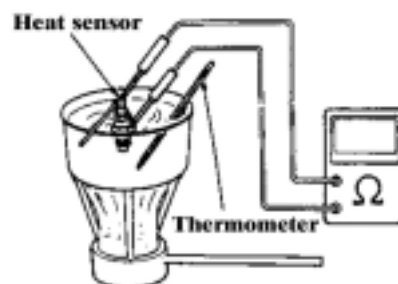

● **Resistance Value**

Temperature ( )	50	80	100	120
Resistance value (Ω)	154	52	27	16

**Note:**

- a) The heat adjuster shouldn't touch the container directly.
- b) If the heat sensor opens at the normal temperature, replace with a new one.
- c) When the temperature adjuster has been open for 5 minutes, measure again at the temperature of 70 .

## 3.8 Carburetor

### 3.8.1 Disassembly Diagram

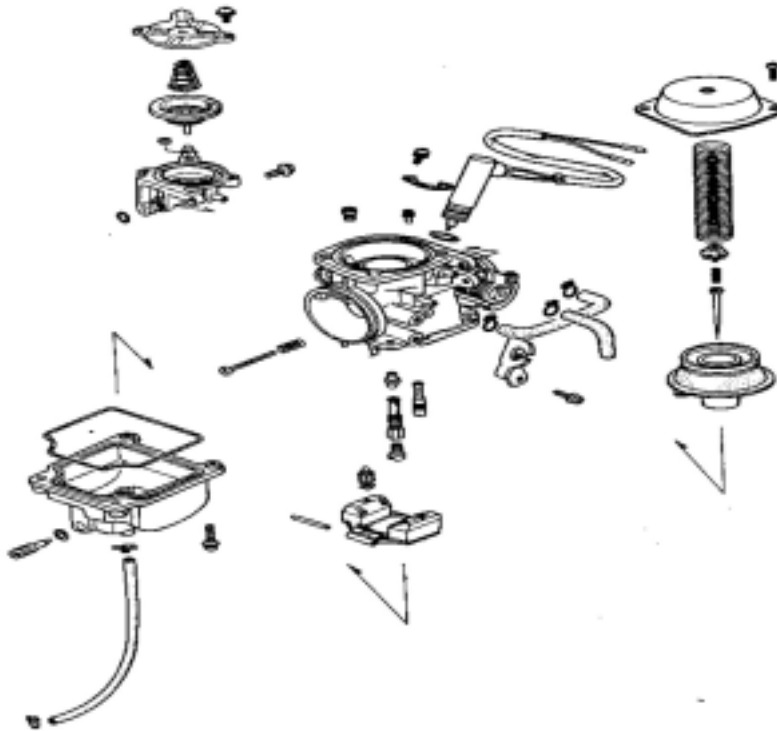

### 3.8.2 Trouble Shooting

- The engine can't start well.
  - a) There is no fuel in the fuel tank.
  - b) The fuel tube is clogged.
  - c) There is too much fuel in the fuel tank.
  - d) The air cleaner is clogged.
  - e) The fuel has deteriorated.
  
- The engine doesn't run stably or smoothly at the idle speed.
  - a) The idle speed hasn't been adjusted well.
  - b) The mixture gas in the carburetor is too rich.
  - c) The mixture gas in the carburetor is too lean.
  - d) The air cleaner is clogged.
  - e) Air is inhaled into the air suction system.
  - f) The fuel has deteriorated.
  - g) The air valve doesn't work well.
  - h) The negative pressure tube is damaged.

- i) The connecting pipe of the carburetor is damaged.
  
- The engine stalls when the throttle is fully open.
  - a) The negative pressure piston film is damaged.
  - b) The negative pressure tube is clogged.
  
- The mixture gas is too lean.
  - a) The fuel jet is clogged.
  - b) The air hole of the fuel tank cover is clogged.
  - c) The fuel filter is clogged.
  - d) The fuel tube is clogged.
  - e) The float valve does not work well.
  - f) The fuel level is too low.
  
- The mixture gas is too rich.
  - a) The automatic choke is opened too widely.
  - b) The float valve doesn't work well.
  - c) The fuel level is too high.
  - d) The air cleaner is clogged.
  - e) The automatic chock isn't assembled correctly.

**3.8.3 Points for Attention**

- a) No smoke or fires in the working places.
- b) Assemble the O-rings correctly and replace with new ones.
- c) Drain out the fuel in the float chamber before disassembly.
- d) Don't disassemble the automatic choke by yourself.

**3.8.4 Specifications**

Pipe Diameter	22mm
Body Mark	BS26-1245
Fuel Level	18.5+/-1.0mm
Air Adjusting Screw	1 3/4
Main Jet	100
Low Speed Jet	# 35
Idle Speed	1500+/-100rpm

**3.8.5 Inspection of Automatic Fuel Cup**

**No smokes or fires!**

- a) Stop the engine and pull the fuel tube from the carburetor;
- b) Check if the fuel flows out;  
 The fuel cup is normal if the fuel stops flowing after all the remaining fuel in the fuel cup and tube (5-10cc) has been drained out;  
 If the fuel continues to flow out, the negative pressure

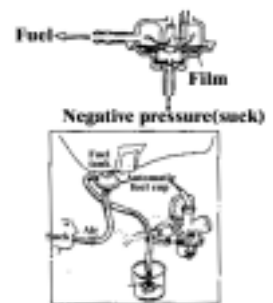

tube is clogged.

- c) Pull the negative pressure tube from the air intake pipe and suck with mouth to produce negative pressure on the vacuum film;  
If when the vacuum film produces negative pressure, the fuel flows out of the fuel tube, and when the negative pressure stops, the fuel stops flowing, then the automatic fuel cup is normal.
- d) If the fuel doesn't flow out when the negative pressure is applied, please follow the following steps: Clear the negative pressure tube if it is clogged;  
Blow the film from the air intake pipe of the automatic fuel cup.

### 3.8.6 Automatic Side Circuit Starter

- a) Check the automatic side circuit starter;  
Check the conduction of all the automatic side circuit starter wires;  
Replace the automatic choke if the resistance value exceeds the standard value.  
Resistance value: below  $10\Omega$  (10 min after the engine stops)
- b) Connect a tube with the fuel-adding line of the carburetor;  
Connect the yellow wire of the choke with the battery + electrode;  
Connect the green wire of the choke with the battery - electrode.  
Blow with mouth after 5 min.  
If the air does not go smoothly, it is normal.  
Remove the automatic choke wire from the battery.  
Blow with mouth after 30 min.  
If the air goes smoothly, it is normal.

### 3.8.7 Inspection of Fuel Level

- a) Check the fuel level of the main jet.
- b) Fuel level:  $18.5\pm 1.0\text{mm}$
- c) Check the float and assemble the float fuel tube.

### 3.8.8 Adjustment of Idle Speed

- a) Adjust the idle speed after warming up the engine.
- b) Close the fuel adjusting screw fully; turn back the standard  $1\frac{3}{4}$  turning.
- c) Adjust the adjusting screw to the specified idle speed.
- d) Turn the adjusting screw left and right slightly.
- e) Repeat the steps 2, 3.
- f) Adjust the throttle adjusting screw to the idle speed position ( $1,500\pm 100\text{rpm}$ ).
- g) Run the engine from the low speed to high speed, run the engine at the idle speed for 10 to 15 seconds to see if the idle speed is stable;  
If it changes, repeat the steps 2-5.



### 3.8.9 Air Cleaner

- Check if the air cleaner is damaged;  
Replace with a new one if necessary.
- Clean the air cleaner every 1,000 km.
- Replace the air cleaner every 5,000km.



### 3.8.10 Ignition Timing

The C.D.I. is used, so there is no need to adjust the ignition timing.  
If the ignition timing is abnormal, check the C.D.I. and AC generator.

#### ● Inspection of Ignition Timing

- Use the ignition timing lamp.
- Align the mark "F" within the range of  $\pm 3^\circ$  at the rotation of 1,700rpm.  
Ignition timing: B.T.D.C  $13^\circ \pm 3$  1700rpm.
- If the rotation is above 3,000rpm, the aligning mark should be located before the advanced ignition mark.



### 3.8.10 Adjustment of Valve Clearance

- Check and adjust the valve clearance when the engine is cold.
- Turn the drive pulley in the left crankcase in the left direction.
- Align the mark of the cam sprocket with the cylinder head cover, and the piston is at T.D.C. (compression top dead point) at this time.
- Adjust the valve clearance to the standard value (0.09-0.11mm) with the special tools.
- Fasten the lifter nut.

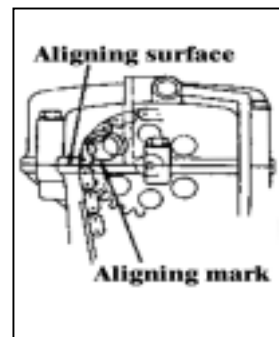
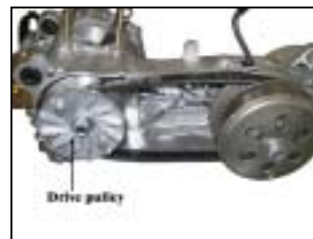

### 3.8.11 Spark Plug

- Check if the spark plug is burnt or dirty.
- Check if there is any carbon on the spark plug.
- Clean the spark plug if necessary.

Specifications: Spark Plug: D7

Spark Plug Gap: 0.6-0.7mm

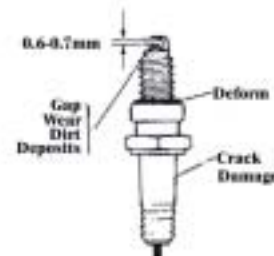

### 3.8.12 Inspection of Compression

- **Compression:** 11.0-15.0kg/cm<sup>2</sup> (400rpm)

#### ● Trouble Shooting

The compression is too low.

- The valve leaks.
- The valve clearance is too big.
- The cylinder head gasket is damaged.
- The piston rings are worn.

e) The piston rings and the cylinder are worn.

The compression is too high.

1. There is too much carbon in the combustion chamber and on the piston head.

# WIRING DIAGRAM

